

JVC

SERVICE MANUAL

MODEL
A-K22

STEREO INTEGRATED AMPLIFIER



No. 2662
Feb. 1983

Safety Precaution

1. The design of this product contains special hardware, many circuits and components specially for safety purposes.
For continued protection, no changes should be made to the original design unless authorized in writing by the manufacturer. Replacement parts must be identical to those used in the original circuits. Service should be performed by qualified personnel only.
2. Alterations of the design or circuitry of the product should not be made. Any design alterations or additions will void the manufacturer's warranty and will further relieve the manufacturer of responsibility for personal injury or property damage resulting therefrom.
3. Many electrical and mechanical parts in the product have special safety-related characteristics. These characteristics are often not evident from visual inspection nor can the protection afforded by them necessarily be obtained by using replacement components rated for higher voltage, wattage, etc. Replacement parts which have these special safety characteristics are identified in the parts list of Service manual. Electrical components having such features are identified by shading on the schematics and by (Δ) on the parts list in Service manual. The use of a substitute replacement which does not have the same safety characteristics as the recommended replacement part shown in the parts list in Service manual may create shock, fire, or other hazards.
4. The leads in the products are routed and dressed with ties, clamps, tubings, barriers and/or the like to be separated from live parts, high temperature parts, moving parts and/or sharp edges for the prevention of electric shock and fire hazard.
When service is required, the original lead routing and dress should be observed, and they should be confirmed to be returned to normal, after re-assembling.

5. Leakage current check
(Safety for electrical shock hazard)
After re-assembling the product, always perform an isolation check on the exposed metal parts of the Products (antenna terminals, knobs, metal cabinet, screw heads, earphone jack, control shafts, etc.) to be sure the product is safe to operate without danger of electrical shock.
Do not use a line isolation transformer during this check.
 - Plug the AC line cord directly into the AC outlet. Using a "Leakage Current Tester", measure the leakage current from each exposed metal part of the cabinet, particularly any exposed metal part having a return path to the chassis, to a known good earth ground (water pipe, etc.). Any leakage current must not exceed 0.5 mA AC (r.m.s.).
 - Alternate check method.
Plug the AC line cord directly into the AC outlet. Use an AC voltmeter having 1,000 ohms per volt or more sensitivity in the following manner. Connect a 1500 Ω 10 W resistor paralleled by a 0.15 μ F AC-type capacitor between an exposed metal part and a known good earth ground (water pipe, etc.). Measure the AC voltage across the resistor with the AC voltmeter.
Move the resistor connection to each exposed metal part, particularly any exposed metal part having a return path to the chassis, and measure the AC voltage across the resistor. Now, reverse the plug in the AC outlet and repeat each measurement. Any voltage measured must not exceed 0.75 V AC (r.m.s.). This corresponds to 0.5 mA AC (r.m.s.).

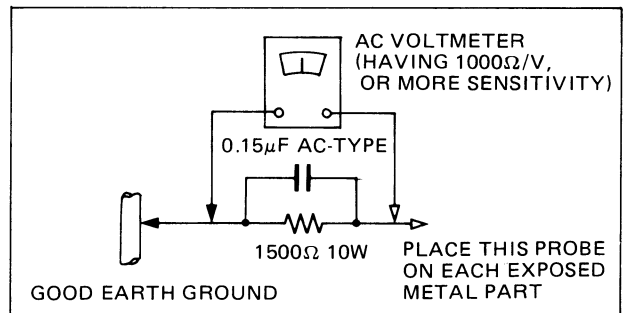

Fig. 1

Contents

Service Precautions	1	4-(5) Power Transistor Section	5
1. Specifications	2	5. Block Diagram	5
2. Main Parts Locations	3	6. Power Amplifier Idling Current Adjustment Procedures	6
2-(1) Top View	3	7. Printed Circuit Board Ass'y and Parts List	6
2-(2) Front View	3	8. A-K22 Schematic Diagram	11
2-(3) Rear View	3	9. Packing Materials and Part Numbers	12
3. Exploded View and Part Numbers	4	10. Accessories List	12
4. Removal Procedures	5	11. Parts List with Specified Numbers for Designated Areas	Back cover
4-(1) Metal Cover Section	5		
4-(2) Front Panel Section	5		
4-(3) Rear Panel Section	5		
4-(4) Checking and Removing the Main P.C. Board	5		

1. Specifications

Output Power	: 40 watts per channel, min. RMS, both channels driven, into 8 ohms from 40 Hz to 20 kHz, with no more than 0.5 % total harmonic distortion	Tone Controls	
	40 watts per channel, min. RMS, both channels driven, into 8 ohms at 1 kHz with no more than 0.7% total harmonic distortion	BASS	: 100 Hz ± 8 dB
	38 watts per channel, min. RMS, both channels driven, into 8 ohms at 1 kHz with no more than 0.01 % total harmonic distortion	TREBLE	: 10 kHz ± 8 dB
Total Harmonic Distortion	: 0.5 % at Rated output, from 40 Hz to 20 kHz, 8 ohms	Input Sensitivity/ Impedance	
	0.01 % at Rated output at 1 kHz, 8 ohms	PHONO	: 2.5 mV/47 kohms
Power Band Width	: 10 Hz – 30 kHz (IHF, both channels driven, 8 ohms, 0.08 % THD)	TUNER, VIDEO/ AUX, TAPE	: 160 mV/40 kohms
Frequency Response	: 10 Hz – 30 kHz +1 dB, -3 dB (8 ohms)	Rec. Output Level	: 150 mV
		Phono Equalizer Deviation	: ±1.0 dB (40 Hz – 20 kHz)
		Phono Overload	: 100 mV (1 kHz)
		Signal to Noise Ratio	
		PHONO	: 67 dB (new IHF) 70 dB (IHF)
		TUNER VIDEO/ AUX, TAPE	: 75 dB (new IHF) 90 dB (IHF)
		Loudness Control	: +5 dB at 100 Hz, (Volume Control at -30 dB position)
		Dimensions (mm/inch)	: 77(H) x 435(W) x 299(D) mm (3-1/16" x 17-3/16" x 11-13/16")
		Weight (kg/lbs)	: 4.3 kg (9.7 lbs)

Power Specifications

Areas	Line Voltage & Frequency	Power Consumption
U.S.A & Canada	AC 120 V, 60 Hz	160 watts, 200 VA
Europe	AC 220 V ~, 50 Hz	280 watts
U.K. & Australia	AC 240 V ~, 50 Hz	280 watts
Other Countries	AC 110/120/220/240 V ~ selectable, 50/60 Hz	320 watts

Design and specifications subject to change without notice.

2. Main Parts Locations

2-(1) Top View

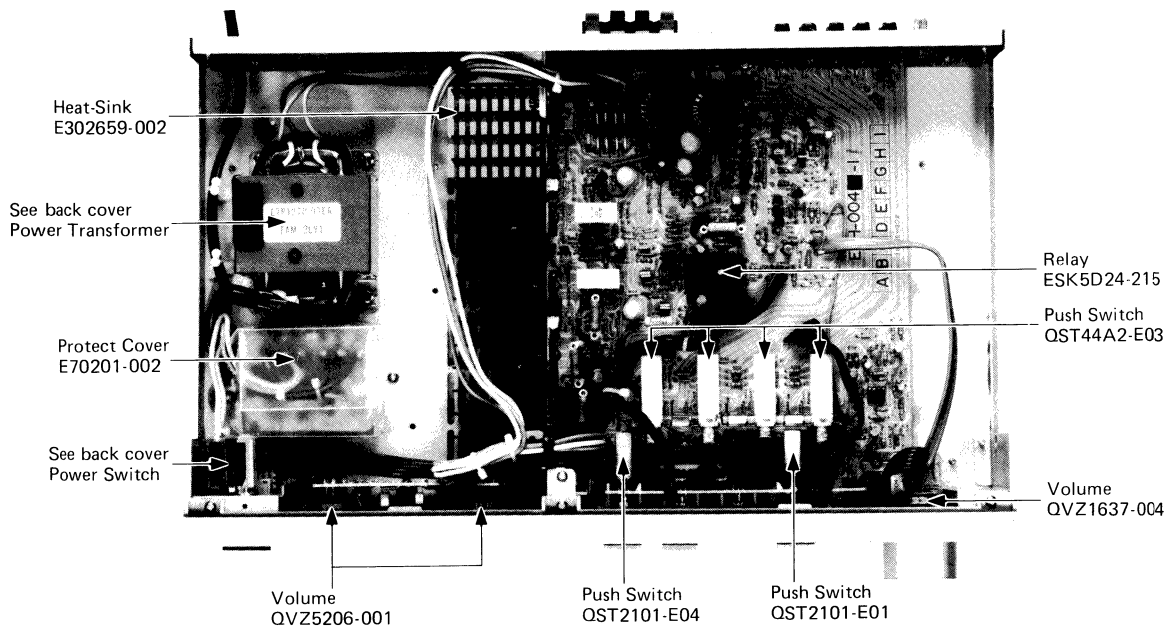

Fig. 2

2-(2) Front View

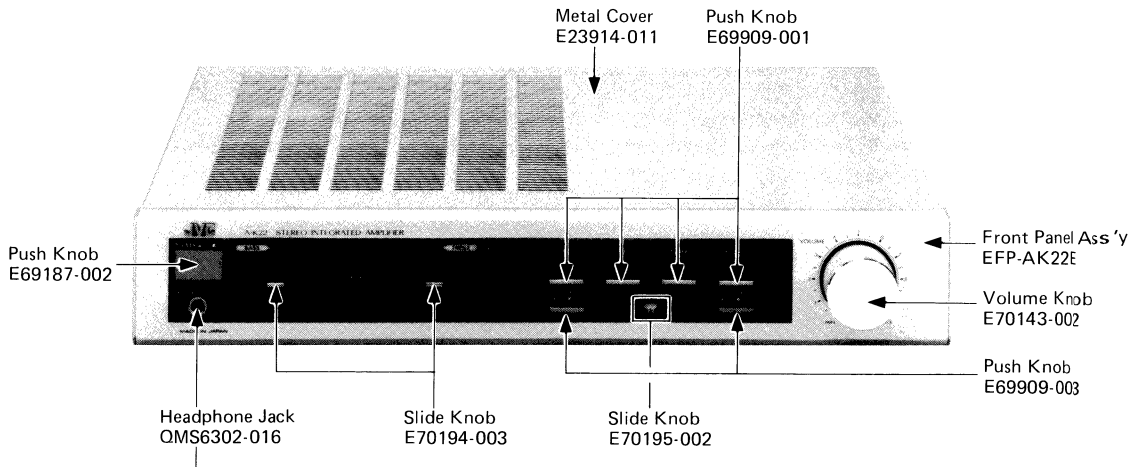

Fig. 3

2-(3) Rear View

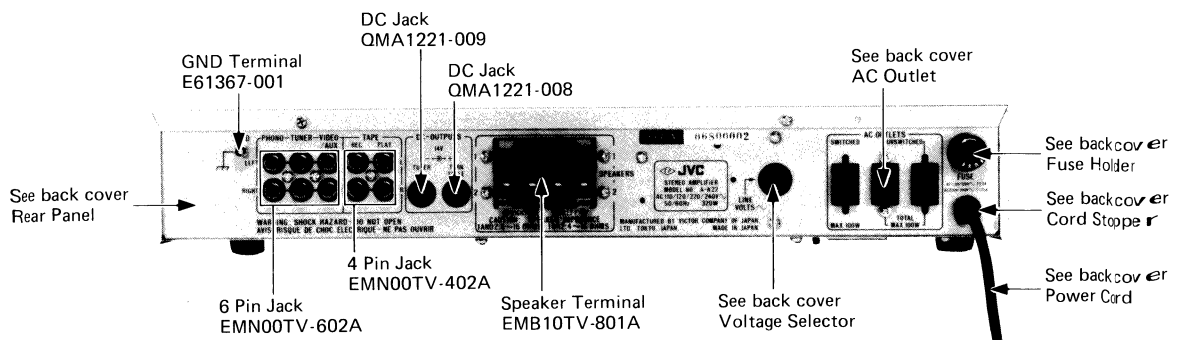

Fig. 4

3. Exploded View and Part Numbers

4. Exploded View and Part Numbers

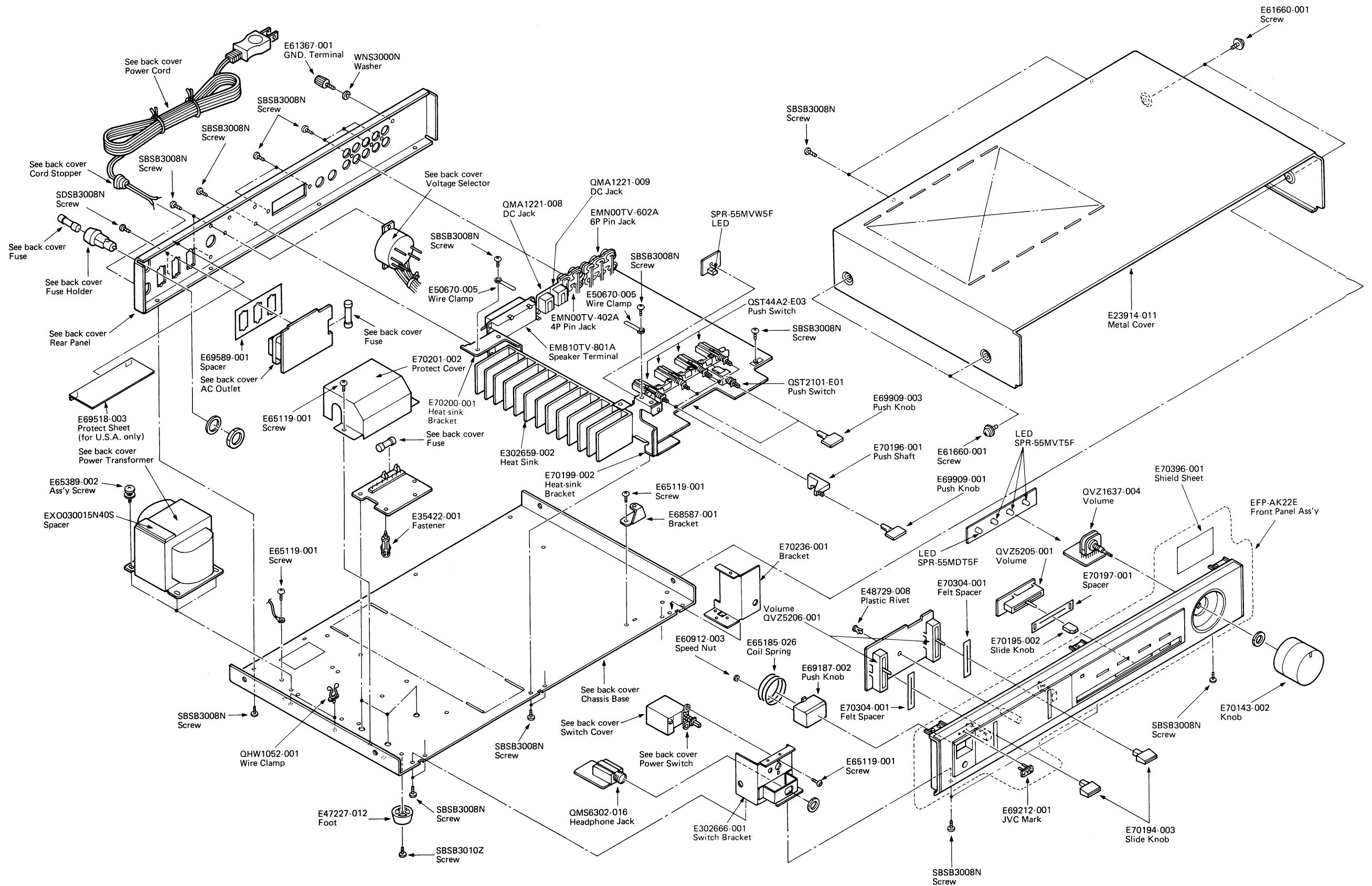

Fig. 5

4. Removal Procedures

NOTE: Also refer to Fig. 5.

4-(1) Metal Cover Section

1. Remove the six screws (provided on the sides and back) which secure the metal cover.
2. Draw off the metal cover backwards carefully.

4-(2) Front Panel Section

1. Remove the metal cover (Refer to Section 4-(1) above).
2. Remove the five screws (provided on the upper/lower sides) which secure the front panel.
3. Pull out the volume knob and remove the nut.
4. Pull out the BASS/TREBLE knobs and detach the front panel from the chassis.
5. Pull out the plastic rivets which secure the TONE P.C. Board.
6. Detach the BALANCE P.C. Board from the front panel catches.

4-(3) Rear Panel Section

1. Remove the metal cover.
2. Remove the eight screws which secure the rear panel from its back side and the four screws which also secure the rear panel from its bottom.

5. Block Diagram

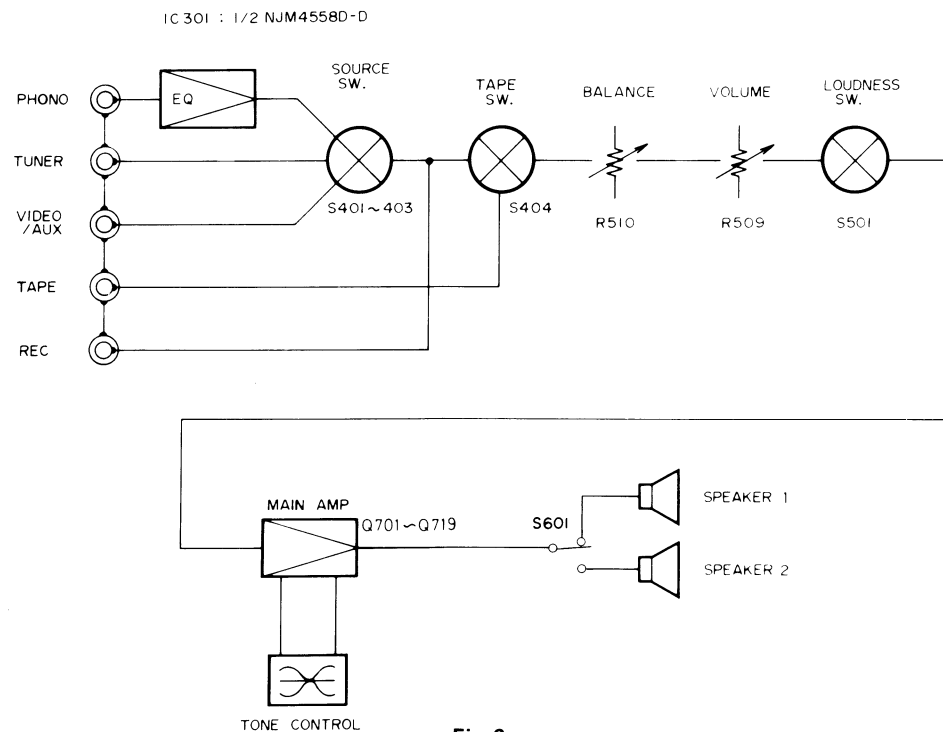

Fig. 6

6. Power Amplifier Idling Current Adjustment Procedures

Adjustment Location on ENH-004 Main Amp. P.C. Board Ass'y

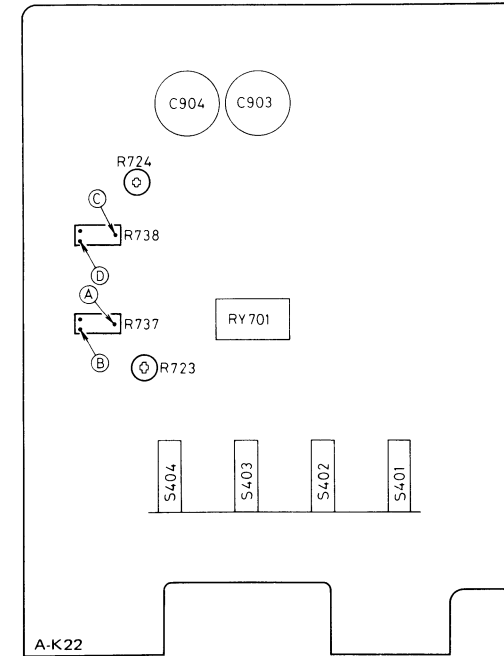

Fig. 7

1. Before turning on the power, turn the semi-fixed resistors <R723 for L channel and R724 for R channel> of the power amplifier circuit board fully counter-clockwise.
2. Adjust the semi-fixed resistors (R723 and R724) so that the voltage at the following test points of the power amplifier circuit board is within a range of 1 mV ~ 3 mV after the power is turned on.
L channel: Measure the voltage between test point (B) (emitter of Q717) and output at the test point (A).
R channel: Measure the voltage between test point (D) (emitter of Q718) and output at the test point (C).
3. Readjust resistors R723 and R724 about 5 minutes after the power is turned on (the heat sink temperature must be sufficiently high) so that the voltage at the test points becomes 10 mV.
Confirm that the voltage does not vary when the heat sink temperature increases further.

7. Printed Circuit Board Ass'y and Parts List

Note: ENH-004 □ varies according to the areas employed. See note (1) when placing an order.

Each Individual P.C. Board Location

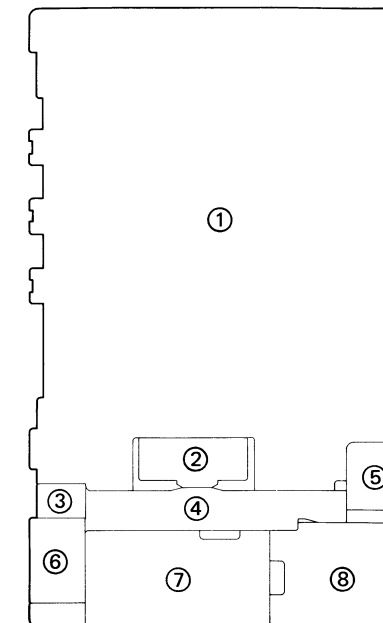

Fig. 8

- ① ENH-004 □ -1 : Main P.C. Board Ass'y
- ② ENH-004-2 : Balance P.C. Board Ass'y
- ③ ENH-004-3 : Power Indicator P.C. Board Ass'y
- ④ ENH-004-4 : Source Indicator P.C. Board Ass'y
- ⑤ ENH-004-5 : Volume P.C. Board Ass'y
- ⑥ ENH-004-6 : Headphone P.C. Board Ass'y
- ⑦ ENH-004-7 : Tone P.C. Board Ass'y
- ⑧ ENH-004-8 : Fuse P.C. Board Ass'y

Note (1)	Designated Areas	P.C. Board Ass'y
	U.S.A. & Canada	ENH-004 A
	Europe & Australia	ENH-004 B
	U.K.	ENH-004 CBS
	West Germany	ENH-004 E
	U.S. Military Market & Other Countries	ENH-004 D

Note (2) The symbols (赤、黒、白... etc.) on P.C. Board surface are factory process only.

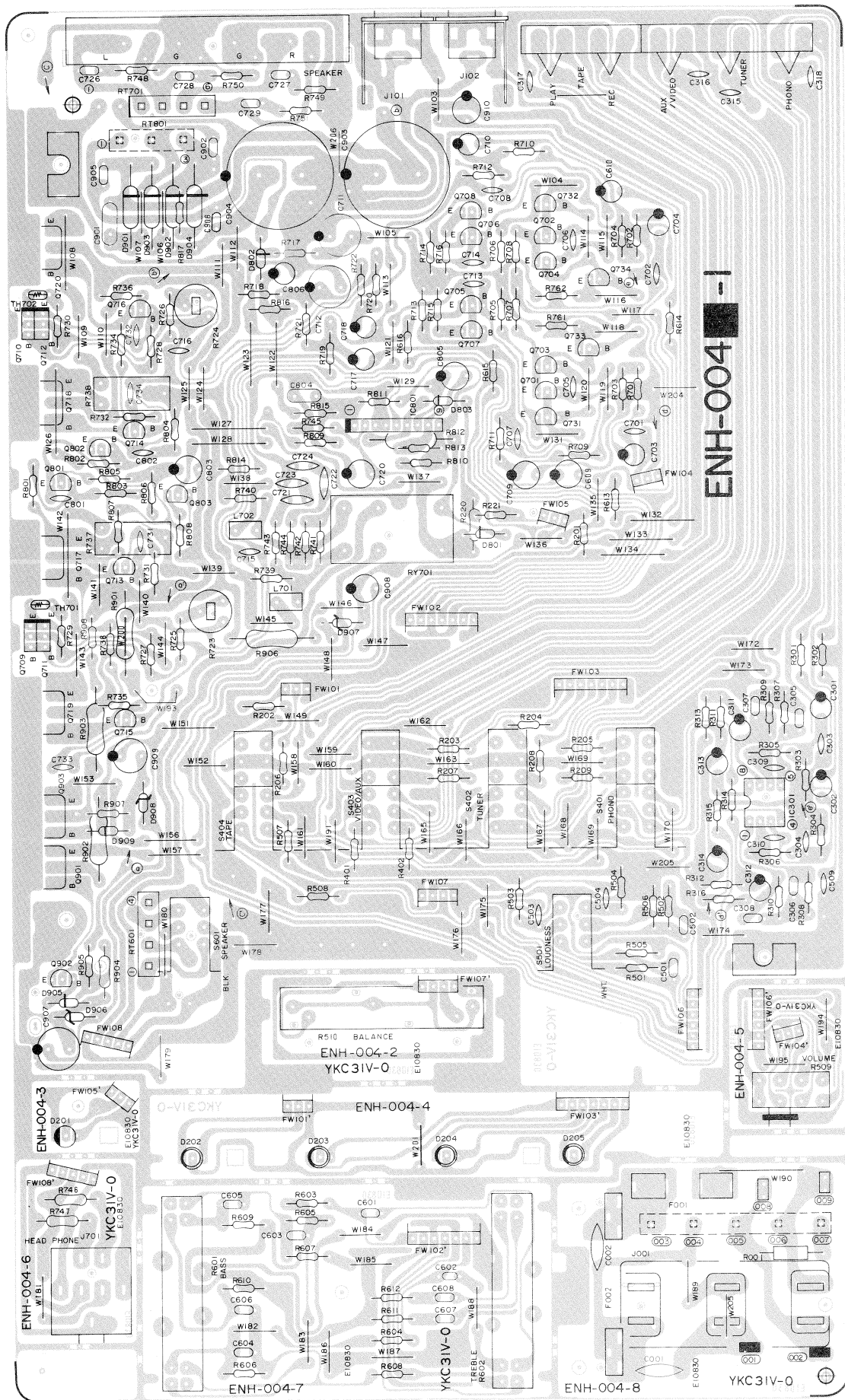

Fig. 9

Transistors

Item No.	Part Number	Rating	Description	
				Maker
Q701	2SC2240(A,B)		Silicon	Toshiba
Q702	2SC2240(A,B)			"
Q703	2SC2240(A,B)			"
Q704	2SC2240(A,B)			"
Q705	2SA872AV(E)			Hitachi
Q706	2SA872AV(E)		"	"
Q707	2SA949(Y)		"	Toshiba
Q708	2SA949(Y)		"	"
Q709	2SD636(Q,R)		"	Matsushita
Q710	2SD636(Q,R)		"	"
Q713	2SC2235(O,Y)		"	Toshiba
Q714	2SC2235(O,Y)		"	"
Q715	2SA965(O,Y)		"	"
Q716	2SA965(O,Y)		"	"
Q717	2SD718(O,Y)		"	"
Q718	2SD718(O,Y)		"	"
Q719	2SB688(O,Y)		"	"
Q720	2SB688(O,Y)		"	"
Q731	2SA733A(P,Q)		"	NEC
Q732	2SA733A(P,Q)		"	"
Q733	2SA733A(P,Q)		"	"
Q734	2SA733A(P,Q)		"	"
Q801	2SC1775AV(E,F)		"	Hitachi
Q802	2SC1775AV(E,F)		"	"
Q803	2SA872AV(E)		"	"
Q901	2SD1265A(P,Q)		"	Matsushita
Q902	2SD438(E,F)		"	Sanyo
Q903	2SD1265A(P,Q)		"	Matsushita

Integrated Circuits

Item No.	Part Number	Rating	Description	
				Maker
IC301	NJM4558D-D			Dainichi
IC801	TA7317P			Toshiba

Diodes

Item No.	Part Number	Rating	Description	
				Maker
D201	SPR-55MVW5F		L.E.D.	Rohm
D202	SPR-55MDT5F			"
D203	SPR-55MVT5F			"
D204	SPR-55MVT5F			"
D205	SPR-55MVT5F			"
D801	2S2473		Silicon	"
D802	1S2473			"
D803	1S2473		"	"
D901	S3V20F		"	Shindengen
D902	S3V20F		"	
D903	S3V20F		"	"
D904	S3V20F		"	"
D905	1S2473		"	Rohm
D906	RD15EB3		"	
D907	RD15EB3		"	NEC
D908	RD15EB3		"	"
D909	1S2473		"	Rohm
D920	1S2076-31		"	
D921	1S2076-31		"	

Coils

Item No.	Part Number	Rating	Description
L701	Y00087-002		Coil
L702	Y00087-002		"

Capacitors

Item No.	Part Number	Rating		Description
C001	QCZ9019-472	4700pF	400V	Ceramic Δ
C002	QCZ9019-472	"	"	" Δ
C301	QET61HM-475	4.7 μ F	50V	Electrolytic
C302	QET61HM-475	"	"	"
C303	QCS31HJ-471	470pF	"	Ceramic
C304	QCS31HJ-471	"	"	"
C305	QFM31HJ-182	1800pF	"	Mylar
C306	QFM31HJ-182	"	"	"
C307	QFM31HJ-682	6800pF	"	"
C308	QFM31HJ-682	"	"	"
C309	QCS31HJ-101	100pF	"	Ceramic
C310	QCS31HJ-101	"	"	"
C311	QET61HM-105	1 μ F	"	Electrolytic
C312	QET61HM-105	"	"	"
C313	QET61EM-226	22 μ F	25V	"
C314	QET61EM-226	"	"	"
C315	QCF31HP-223	0.022 μ F	50V	Ceramic
C316	QCF31HP-223	"	"	"
C317	QCF31HP-223	"	"	"
C318	QCF31HP-223	"	"	"
C501	QFM31HJ-273	0.027 μ F	"	Mylar
C502	QFM31HJ-273	"	"	"
C503	QCS31HJ-271	220pF	"	Ceramic
C504	QCS31HJ-271	"	"	"
C601	QFM31HJ-182	1800pF	"	Mylar
C602	QFM31HJ-182	"	"	"
C603	QFM31HJ-333	0.033 μ F	"	"
C604	QFM31HJ-333	"	"	"
C605	QEN61HM-224	0.22 μ F	"	N.P. Electrolytic
C606	QEN61HM-224	"	"	"
C607	QFM31HJ-183	0.018 μ F	"	Mylar
C608	QFM31HJ-183	"	"	"
C609	QET61HM-475	4.7 μ F	"	Electrolytic
C610	QET61HM-475	"	"	"
C701	QCS31HJ-680	68pF	"	Ceramic
C702	QCS31HJ-680	"	"	"
C703	QET61HM-225	2.2 μ F	"	Electrolytic
C704	QET61HM-225	"	"	"
C705	QCS31HJ-221	220pF	"	Ceramic
C706	QCS31HJ-221	"	"	"
C707	QCS31HJ-100	10pF	"	"
C708	QCS31HJ-100	"	"	"
C709	QET61AM-107	100 μ F	10V	Electrolytic
C710	QET61AM-107	"	"	"
C711	QET51HM-227	220 μ F	50V	"
C712	QET51HM-107	100 μ F	"	"
C713	QCS31HJ-390	39pF	"	Ceramic
C714	QCS31HJ-390	"	"	"
C715	QCF31HP-103	0.01 μ F	"	"
C716	QCF31HP-103	"	"	"
C717	QET61HM-226	22 μ F	"	Electrolytic
C718	QET61HM-226	"	"	"
C720	QET61AM-107	100 μ F	10V	"
C721	QFM31HJ-473	0.047 μ F	50V	Mylar
C722	QFM31HJ-473	"	"	"
C723	QFM31HJ-473	"	"	"
C724	QFM31HJ-473	"	"	"
C726	QFM31HJ-103	0.01 μ F	"	"
C727	QFM31HJ-103	"	"	"
C728	QFM31HJ-103	"	"	"
C729	QFM31HJ-103	"	"	"
C731	QCF31HJ-220	22pF	"	Ceramic
C732	QCF31HJ-220	"	"	"
C733	QCF31HJ-220	"	"	"
C734	QCF31HJ-220	"	"	"
C910	QET51HM-107	100 μ F	"	Electrolytic

Δ : Safety parts

Capacitors

Item No.	Part Number	Rating		Description
C803	QET61HM-226	22 μ F	50V	Electrolytic
C804	QFM31HJ-103	0.01 μ F	"	Mylar
C805	QET61CM-226	22 μ F	16V	Electrolytic
C806	QET61HM-105	1 μ F	50V	"
C901	QFM82AK-103	0.01 μ F	100V	Mylar
C902	QFM82AK-103	"	"	"
C903	QEZ0061-478	4700 μ F	50V	Electrolytic
C904	QEZ0061-478	"	"	"
C907	QET61EM-107	100 μ F	25V	"
C908	QET61EM-107	"	"	"
C909	QET61EM-107	"	"	"
C920	QCF31HP-103	0.01 μ F	50V	Ceramic

Resistors

Item No.	Part Number	Rating		Description
R001	QRC128K-275EM	2.7M Ω	$\frac{1}{4}$ W	Composition Δ
R201	QRD141J-821S	820 Ω	$\frac{1}{4}$ W	Carbon
R202	QRD141J-821S	"	"	"
R203	QRD141J-821S	"	"	"
R204	QRD141J-821S	"	"	"
R205	QRD141J-821S	"	"	"
R206	QRD141J-821S	"	"	"
R207	QRD141J-821S	"	"	"
R208	QRD141J-821S	"	"	"
R209	QRD141J-821S	"	"	"
R220	QRG012J-392A	3.9k Ω	1W	O.M. Film Δ
R221	QRD141J-821S	820 Ω	$\frac{1}{4}$ W	Carbon
R301	QRD141J-222S	2.2k Ω	"	"
R302	QRD141J-222S	"	"	"
R303	QRD141J-473S	47k Ω	"	"
R304	QRD141J-473S	"	"	"
R305	QRD141J-681S	680 Ω	"	"
R306	QRD141J-681S	"	"	"
R307	QRD141J-393S	39k Ω	"	"
R308	QRD141J-393S	"	"	"
R309	QRD141J-474S	470k Ω	"	"
R310	QRD141J-474S	"	"	"
R311	QRD141J-104S	100k Ω	"	"
R312	QRD141J-104S	"	"	"
R313	QRD141J-471S	470 Ω	"	"
R314	QRD141J-471S	"	"	"
R315	QRD145J-221S	220 Ω	"	Unf. Carbon Δ
R316	QRD145J-221S	"	"	" Δ
R401	QRD141J-332S	3.3k Ω	"	Carbon
R402	QRD141J-332S	"	"	"
R501	QRD141J-683S	68k Ω	"	"
R502	QRD141J-683S	"	"	"
R503	QRD141J-224S	220k Ω	"	"
R504	QRD141J-224S	"	"	"
R505	QRD141J-223S	22k Ω	"	"
R506	QRD141J-223S	"	"	"
R507	QRD141J-472S	4.7k Ω	"	"
R508	QRD141J-472S	"	"	"
R509	QVZ1637-004	250k Ω (B)		Variable (Volume)
R510	QVZ5205-001	" (W)		" (Balance)
R601	QVZ5206-001	100k Ω (B)		" (Bass)
R602	QVZ5206-001	" (")		" (Treble)
R603	QRD141J-123S	12k Ω	$\frac{1}{4}$ W	Carbon
R604	QRD141J-123S	"	"	"
R605	QRD141J-823S	82k Ω	"	"
R606	QRD141J-823S	"	"	"
R607	QRD141J-182S	1.8k Ω	"	"
R608	QRD141J-182S	"	"	"
R609	QRD141J-182S	"	"	"
R610	QRD141J-182S	"	"	"

Δ : Safety parts

Resistors

Item No.	Part Number	Rating		Description
R611	QRD141J-561S	560 Ω	$\frac{1}{4}$ W	Carbon
R612	QRD141J-561S	"	"	"
R613	QRD141J-562S	5.6k Ω	"	"
R614	QRD141J-562S	"	"	"
R615	QRD141J-472S	4.7k Ω	"	"
R616	QRD141J-472S	"	"	"
R701	QRD141J-222S	2.2k Ω	"	"
R702	QRD141J-222S	"	"	"
R703	QRD141J-104S	100k Ω	"	"
R704	QRD141J-104S	"	"	"
R705	See page 10	100 Ω	"	Unf. Carbon Δ
R706	See page 10	"	"	" Δ
R707	QRD141J-822S	8.2k Ω	"	Carbon
R708	QRD141J-822S	"	"	"
R709	QRD141J-681S	680 Ω	"	"
R710	QRD141J-681S	"	"	"
R711	QRD141J-104S	100k Ω	"	"
R712	QRD141J-104S	"	"	"
R713	QRD141J-272S	2.7k Ω	"	"
R714	QRD141J-272S	"	"	"
R715	QRD149J-330S	33 Ω	"	Unf. Carbon Δ
R716	QRD149J-330S	"	"	" Δ
R717	QRD149J-181S	180 Ω	"	" Δ
R718	QRD149J-221S	220 Ω	"	" Δ
R719	QRD141J-472S	4.7k Ω	"	Carbon
R720	QRD141J-472S	"	"	"
R721	QRD141J-272S	2.7k Ω	"	"
R722	QRD141J-272S	"	"	"
R723	QVZ3501-222	2.2k Ω	"	Variable (Semi-fix)
R724	QVZ3501-222	"	"	" (")
R725	QRD141J-821S	820 Ω	$\frac{1}{4}$ W	Carbon
R726	QRD141J-821S	"	"	"
R727	QRD141J-102S	1k Ω	"	"
R728	QRD141J-102S	"	"	"
R731	QRD145J-100S	10 Ω	"	Unf. Carbon Δ
R732	QRD145J-100S	"	"	" Δ
R733	QRD145J-271S	270 Ω	"	" Δ
R734	QRD145J-271S	"	"	" Δ
R735	QRD145J-100S	10 Ω	"	" Δ
R736	QRD145J-100S	"	"	" Δ
R737	ERF032K-R47	0.47 Ω	3W	Cement Δ
R738	ERF032K-R47	"	"	" Δ
R739	QRD145J-330S	33 Ω	$\frac{1}{4}$ W	Unf. Carbon Δ
R740	QRD145J-330S	"	"	" Δ
R741	QRD141J-104S	100k Ω	"	Carbon
R742	QRD141J-100S	"	"	"
R743	QRD145J-100S	10 Ω	"	Unf. Carbon Δ
R744	QRD145J-100S	"	"	" Δ
R745	QRD141J-104S	100k Ω	"	Carbon
R746	QRD129J-221S	220 Ω	$\frac{1}{4}$ W	Unf. Carbon Δ
R747	QRD129J-221S	"	"	" Δ
R748	QRZ0052-100	10 Ω	$\frac{1}{4}$ W	Fusible Δ
R749	QRZ0052-100	"	"	" Δ
R750	QRZ0052-100	"	"	" Δ
R751	QRZ0052-100	"	"	" Δ
R761	QRD145J-101S	100 Ω	"	Unf. Carbon Δ
R762	QRD145J-101S	"	"	" Δ
R801	QRD141J-222S	2.2k Ω	"	Carbon
R802	QRD141J-222S	"	"	"
R803	QRD141J-102S	1k Ω	"	"
R804	QRD141J-102S	"	"	"
R805	QRD141J-123S	12k Ω	"	"
R806	QRD141J-123S	"	"	"
R807	QRD141J-103S	10k Ω	"	"
R808	QRD141J-332S	3.3k Ω	"	"

Δ : Safety parts

Resistor

Item No.	Part Number	Rating		Description
R809	QRD141J-563S	56kΩ	¼W	Carbon
R810	QRD141J-183S	18kΩ	"	"
R811	QRD141J-683S	68kΩ	"	"
R812	See below	560Ω	2W	O.M. Film Δ
R813	QRD141J-224S	220kΩ	¼W	Carbon
R814	QRD141J-123S	12kΩ	"	"
R815	QRD141J-223S	56kΩ	"	"
R816	QRD141J-123S	12kΩ	"	"
R817	QRD145J-123S	"	"	Unf. Carbon Δ
R901	See below	22Ω	3W	O.M. Film Δ
R902	See below	"	"	" Δ
R903	QRD145J-8R2S	8.2Ω	¼W	Unf. Carbon Δ
R904	QRD125J-272S	2.7kΩ	¼W	" Δ
R905	See below	100Ω	¼W	Fusible Δ
R906	QRG027J-152	1.5kΩ	2W	O.M. Film Δ
R907	QRD129J-272S	2.7kΩ	½W	Unf. Carbon Δ
R908	QRD145J-8R2S	8.2Ω	¼W	" Δ

Δ : Safety parts

Others

Item No.	Part Number	Rating	Description
	E10830-202		Circuit Board
	E10830-202BS		"
	EMN00TV-402A		Pin Jack Ass'y
	EMN00TV-602A		"
	EMB10TV-801A		Speaker Terminal
	E70199-002		Heat Sink Bracket
	E70200-001		"
	SBSB3012Z		Tapping Screw
	E302659-002		Heat Sink
	E65654-001		Spacer
F001	E65396-001		Earth Plate
F002	E70230-001		Volume Plate
J001	EMG7331-001		Fuse Clip Δ
	E03675-004		" Δ
	QMC0637-004		AC Socket Δ
J101	QMA1221-008		DC Terminal Δ
J102	QMA1221-009		" Δ
J701	QMS6302-016		Headphone Jack
S401	QST44A2-E03		Push Switch
			(Source Select)
S501	QST2101-E01		Push Switch
			(Loudness)
S601	QST2101-E04		Push Switch
			(Speaker Select)
RY701	ESK5D24-215		Relay
TH701	SDT250		Thermistor
TH702	SDT250		"

Δ : Safety parts

Specified Numbers in ENH-004 for Designated Areas

Item No.	Description	U.S.A. & Canada	Australia	Europe	U.K.	West Germany	U.S. Military Market & Other Countries
—	Circuit Board	E10830-202	E10830-202	E10830-202	E10830-202BS	E10830-202	E10830-202
C303,304	Ceramic Capacitor	—	—	—	—	QCS31HJ-471	—
C315~317	" "	—	—	—	—	QCF31HP-223	—
C726~729	Mylar Capacitor	—	—	—	—	QFM31HJ-103	—
R001	Composition Resistor Δ	QRC128K-275EM	—	—	—	—	—
R705,706	Carbon Resistor	QRD145J-101S	QRD141J-182S	QRD141J-182S	QRD141J-182S	QRD141J-182S	QRD141J-182S
R748~751	Fusible Resistor Δ	—	—	—	—	QRZ0052-100	—
R761,762	UNF Carbon Resistor	QRD145J-101S	—	—	—	—	—
R812	O.M. Film Resistor Δ	QRG027J-561	QRG026J-561	QRG026J-561	QRG026J-561	QRG026J-561	QRG027J-561
R901,902	" " Δ	QRG032J-220	QRG036J-220	QRG036J-220	QRG036J-220	QRG036J-220	QRG036J-220
R905	Carbon or Fusible Δ	QRG145J-101S	QRZ0052-101	QRZ0052-101	QRZ0052-101	QRZ0052-101	QRD145J-101S
—	Fuse Clip (F001)	—	EMG7331-001	EMG7331-001	EMG7331-001	EMG7331-001	—
—	" (F002)	E03675-004	—	—	—	—	—

Δ : Safety parts

8. A-K22 Schematic Diagram

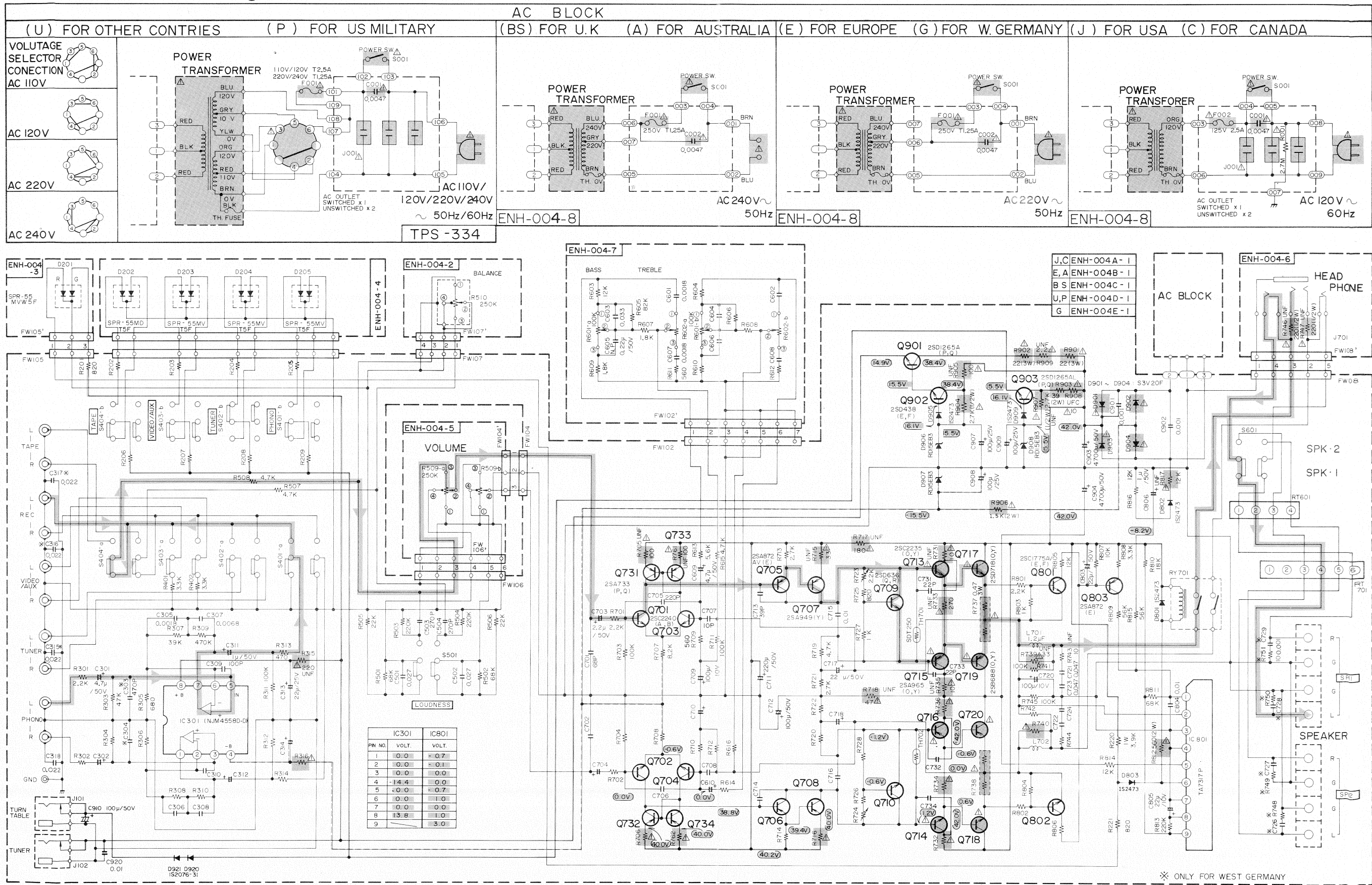

Printed Circuit Board Ass'y Location

P.C. Board Ass'y	Description	Page
ENH-004	P.C. Board Ass'y	6

Notes:

- When replacing the parts in the darkened area and those marked with Δ , be sure to use the designated parts to ensure safety.
- Indicates signal path.
- Indicates positive B power supply.
- 3.0 shows voltage values at no signal.
- This is the standard circuit diagram. The design and contents are subject to change without notice.

9. Packing Materials and Part Numbers

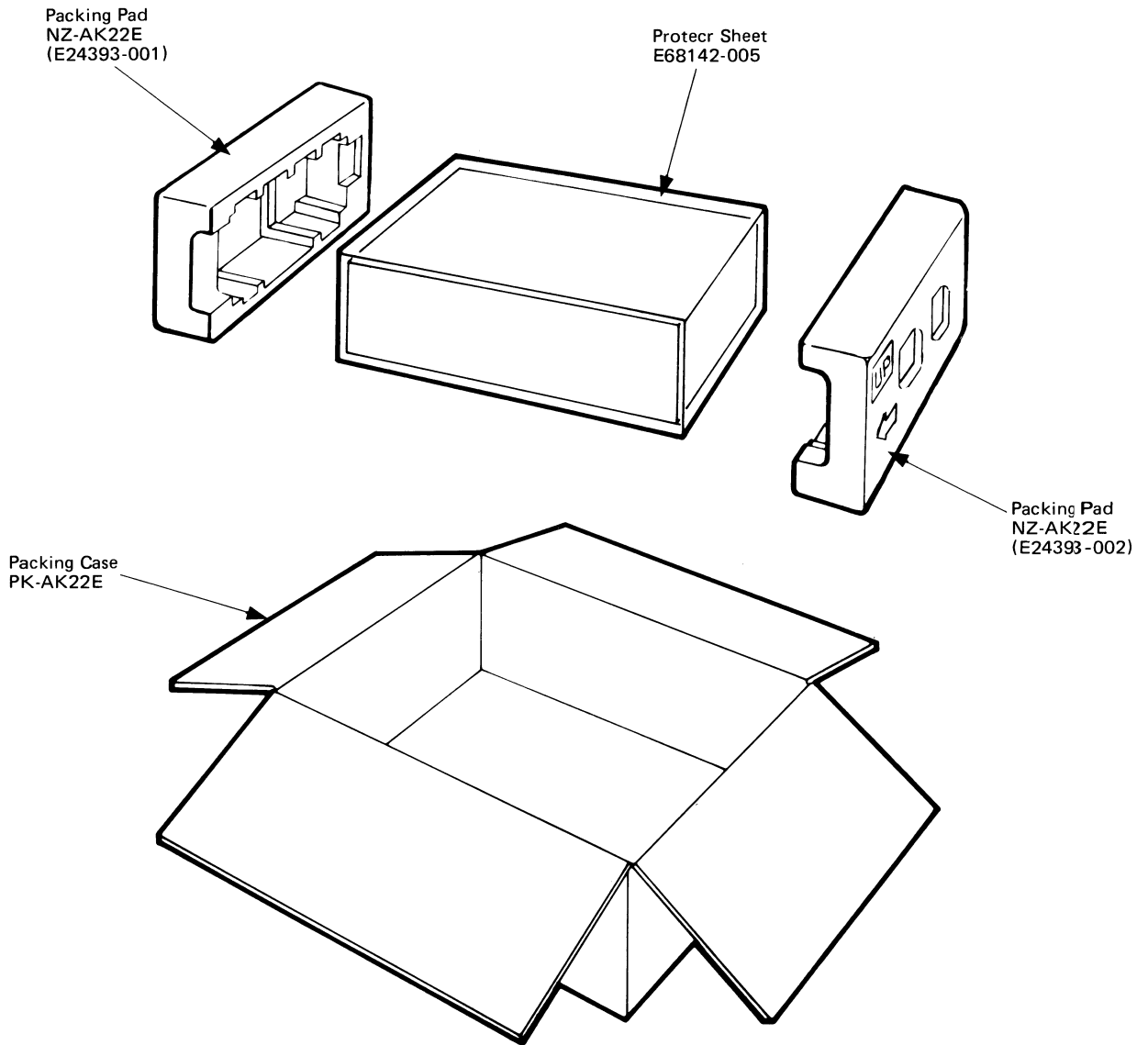

Fig. 10

10. Accessories List

Item No.	Part Number	Description	Qty
1	E30580-1106B	Instruction Book (for U.K., E30580-1106BBS)	1
2	See back cover	Warranty Card	1
3	E41202-2	Envelope for Instruction Book & Warranty Card	1
4	See back cover	Service Information Card	1
5	See back cover	Fuses (Within)	1
6	E64204-073	Envelope for Fuses (Within)	1
7	BT20044D	JVC Safety Instruction Sheet (for U.S.A. only)	1
8	See back cover	Siemens Plug	1

11. Parts List with Specified Numbers for Designated Areas

Item No.	Description	U.S.A. & Canada	Australia	Europe	U.K.	West Germany	U.S. Military Market & Other Countries
1	Power Transformer Δ	ETP1070-07JA (U.S.A.) ETP1070-07CA (Canada)	ETP1070-07EA	ETP1070-07EA	ETP1070-07EABS	ETP1070-07EA	ETP1070-07FA
2	Power Switch Δ	QSP1110-308	QSP1110-305	QSP1110-305	QSP1110-305BS	QSP1110-305	QSP1110-305
3	Main P.C. Board	ENH-004A	ENH-004B	ENH-004B	ENH-004CBS	ENH-004E	ENH-004D
4	Rear Panel	E24391-006	E24391-005	E24391-005	E24391-005	E24391-005	E24391-007
5	Voltage Selector Δ	—	—	—	—	—	QSR0085-001U
6	Power Cord Δ	QMP1200-200	QMP2560-244	QMP3900-200	QMP9017-008BS	QMP3900-200	QMP7600-250
7	Cord Stopper Δ	QHS3876-162	QHS3876-162	QHS3876-162	QHS3876-162BS	QHS3876-162	QHS3876-162
8	Fuse Holder Δ	—	—	—	—	—	QMG0301-003
9	Fuse (Within) Δ	—	—	—	—	—	QMF51A2-1R25L or QMF51A2-2R5L
10	Fuse (Primary) Δ	QMF61U1-2R5	QMF51A2-1R25L	QMF51A2-1R25L	QMF51A2-1R25LBS	QMF51A2-1R25L	QMF51A2-1R25L or QMF51A2-2R5L
11	Chassis Base	E10672-010	E10672-011	E10672-011	E10672-011	E10672-011	E10672-010
12	AC Outlet Δ	QMC0637-004	—	—	—	—	QMC0637-004
13	Switch Cover	—	E301869-002	E301869-002	E301869-002	E301869-002	E301869-002
14	Warranty Card	BT20048 (U.S.A.) or BT20025F (Canada)	BT20029C	—	BT20013C	BT20057	BT20048 (U.S. Military Market)
15	Service Information Card	BT20046A (U.S.A.)	—	—	—	—	BT20046A (U.S. Military Market)
16	Siemens Plug	—	—	—	—	—	E04056
17	Information Sheet	—	—	—	—	BT20054-006A	—

Δ : Safety parts

JVC

VICTOR COMPANY OF JAPAN, LIMITED, TOKYO, JAPAN



Printed
5802-